

PCB parts placement diagram:

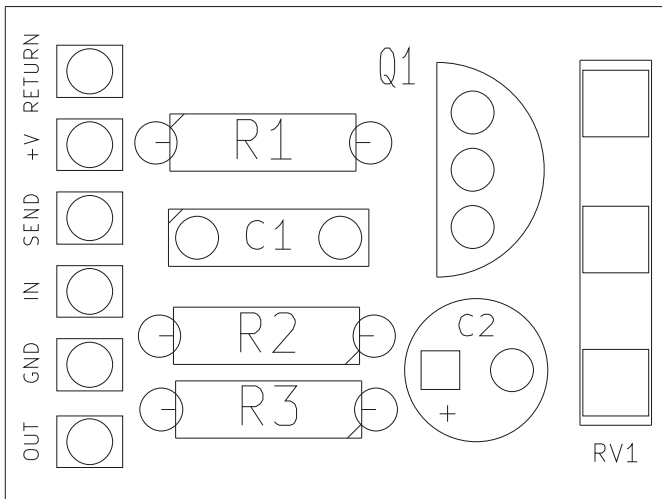

- R1 2M2
- R2 2M2
- R3 4k7

- RV1 B50k

- C1 33n
- C2 10u

- Q1 J201

Wiring (bottom view):

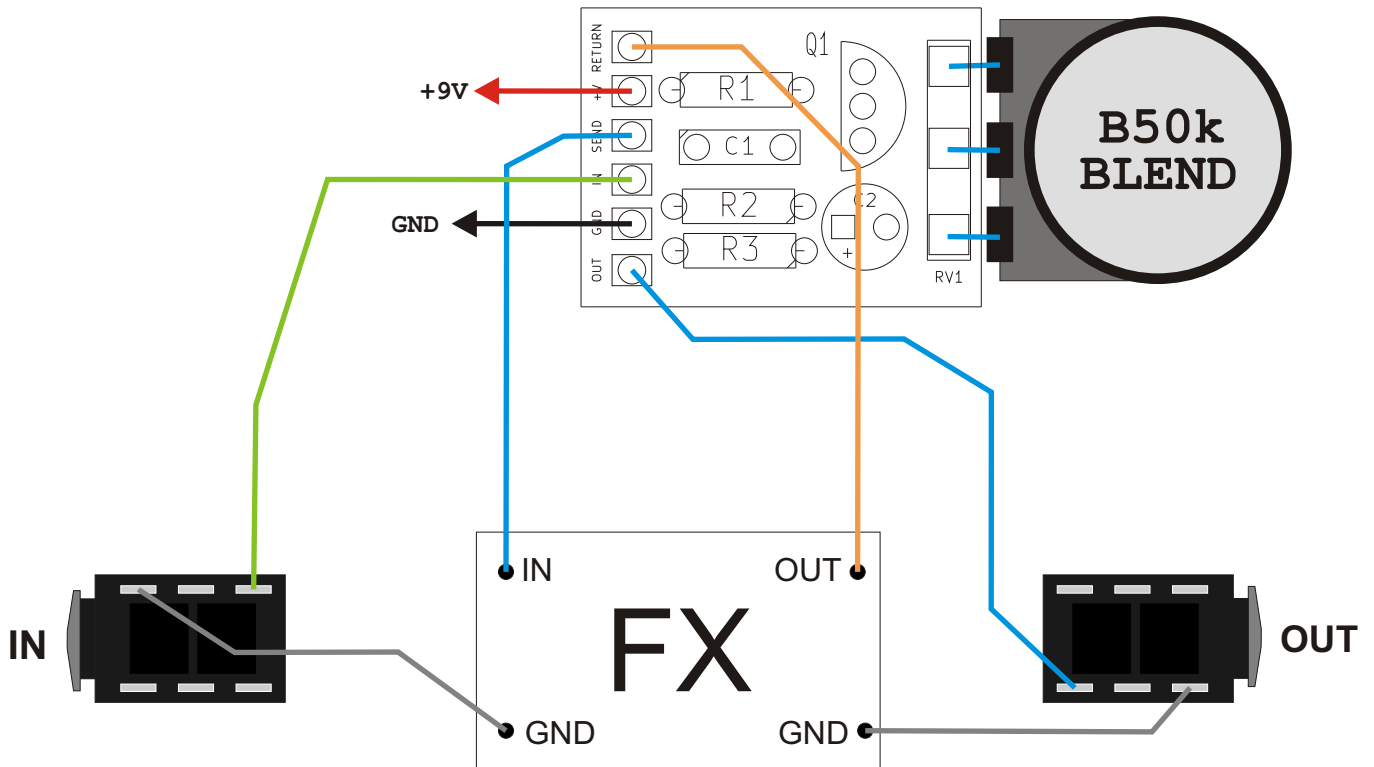

Use metal enclosure connected to ground.
Power supply: 9V DC

Bill of materials:

Resistors:

4k7 1pcs. "R3"
2M2 2pcs. "R1 R2"

Potentiometers:

B50k 1pcs. "RV1"

Other:

Knob 1pcs.

Capacitors:

33n 1pcs. "C1"

Electrolytic capacitors:

10u 1pcs. "C2"

Semiconducors:

J201 1pcs. "Q1"

Resistor color code:

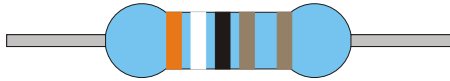

$$390 \times 10\Omega = 3,9k\Omega$$

Color	Band 1	Band 2	Band 3	Multiplier	Tolerance
Black	0	0	0	1 Ω	
Brown	1	1	1	10 Ω	1%
Red	2	2	2	100 Ω	2%
Orange	3	3	3	1k Ω	
Yellow	4	4	4	10 k Ω	
Green	5	5	5	100 k Ω	0,5%
Blue	6	6	6	1 M Ω	0,25%
Purple	7	7	7	10 M Ω	0,1%
Gray	8	8	8	100 M Ω	0,05%
White	9	9	9	1 G Ω	
Gold				0,1 Ω	5%
Silver				0,01 Ω	10%

Capacitors markings:

$$471 = 47 \times 10^1 \text{ pF} = 470 \text{ pF}$$

$$472 = 47 \times 10^2 \text{ pF} = 4700 \text{ pF} = 4,7 \text{ nF}$$

$$473 = 47 \times 10^3 \text{ pF} = 47000 \text{ pF} = 47 \text{ nF}$$

$$474 = 47 \times 10^4 \text{ pF} = 470000 \text{ pF} = 470 \text{ nF}$$

$$100 \text{ pF} = 100 \text{ p} = 100 = 101$$

$$220 \text{ pF} = 220 \text{ p} = 220 = 221$$

$$4,7 \text{ nF} = 4 \text{ n}7 = 0.0047 = 472$$

$$10 \text{ nF} = 10 \text{ n} = 0.01 = 103$$

$$100 \text{ nF} = 100 \text{ n} = 0.1 = 104$$

$$220 \text{ nF} = 220 \text{ n} = 0.22 = 224$$

$$470 \text{ nF} = 470 \text{ n} = 0.47 = 474$$

$$1000 \text{ nF} = 1 \mu\text{F} = 1 \mu = 105$$